



























## Appendix A1

Floor - Table of Difficulty					
To get the Difficulty value for the element it must fulfil all the difficulty requirements for the specific element					
1 Balances		The text contains the definition of the element and the picture is a guideline			
1.1 A Dynamic Balances - Pirouettes					
<p>The Pirouette must be performed on one foot, on toes. The turn must not be done by jumping, but a slight hop to maintain balance during the pirouette is allowed. The rotation must be totally fulfilled, measured at the hips. The tolerance for any under or over rotation at the start and/or the end of an element is 45° in total.</p> <p>Optional placement of the free leg and arms. The free leg can be straight or bent but must be same for the whole team. The position of the supporting leg, bent/straight, does not change the DV, but must be the same for the whole team. The number of turns and height of the free leg define the value of the element.</p> <p>A pirouette starts when the free leg and the heel is lifted from the ground and is finished when the rotation is over, the heel of the supporting leg touches the floor or the free leg touches the floor. The body shape must be correct, no leaning/arching (15° tolerance). The leg separation requirement must be fulfilled (15° tolerance) and the free leg must be held in the correct position for at least ¾ of the rotation. Showing additional flexibility does not affect the difficulty value. All gymnasts must start the turn facing the same direction, according to the choreography. No need to perform pirouettes with the same leg.</p> <p>A forward pirouette means turning in the same direction to the supporting leg.</p> <p>A backward pirouette means turning in the opposite direction to the supporting leg.</p>					
Pirouettes	0.2	0.4	0.6	0.8	1.0
Forwards	DB201   360°		DB601   540°	DB801   720°	DB1001   900°
Backwards	DB202   360°		DB602   540°	DB802   720°	DB1002   900°





Pirouettes continued	0.2	0.4	0.6	0.8	1.0
<p><b>Forwards</b> Free leg with hand support 90°. When the free leg is bent the heel is used to define the angle to the hip.</p>		<p>DB403 </p>  <p>360°</p>		<p>DB803 </p>  <p>540°</p>	<p>DB1003 </p>  <p>720°</p>
<p><b>Forwards</b> Free leg without hand support 90°. When the free leg is bent the heel is used to define the angle to the hip.</p>			<p>DB604 </p>  <p>360°</p>		<p>DB1004 </p>  <p>540°</p>







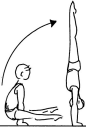

### 1.1 B Dynamic Balances - Power Elements

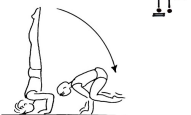
Handstand as a starting or ending position must have straight arms (45° tolerance), straight legs together (15° tolerance) and straight hips.

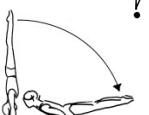
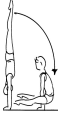
There must be a controlled and continuous movement showing dynamic strength. The movement must be performed by using muscle power, not by the gravity (not too fast lowering). No pause  $\geq 3$  sec allowed. No fall or more than one step allowed. E.g. in lowering from the handstand to straddle pike sitting must be slower than just gravity taking the gymnast down. Starting and ending positions must be clearly visible, but do not need be held for two seconds. All gymnasts perform the same power element with arms and legs in the same position. The body position must be according to the definition of the element, e.g. straight arms and legs together when required.







No supportive weight on the legs during the power elements.

Power Elements	0.2	0.4	0.6	0.8	1.0
<b>Press up to handstand</b> With split straight legs (DB805). Starting position is optional.				DB805 	
<b>Press up to handstand</b> With straight legs together (DB1006). Starting position is optional.					DB1006 
<b>Press up to handstand from straddle pike sitting support</b> From a straddle pike sitting support press to handstand with straight legs.					DB1007 
<b>Press up to handstand from pike sitting support</b> From a pike sitting support press to handstand. Bending legs in the first part is allowed, after passing the hands, press to handstand is performed with straight legs together or straight split legs.					DB1008 

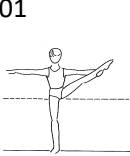
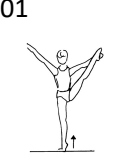
Power Elements continued	0.2	0.4	0.6	0.8	1.0
<b>Headstand to planche</b> From a controlled headstand, body straight, lowering to a planche on elbows. Legs together and straight (not in DB409).		DB409  headstand to frog	DB609  headstand to planche		
<b>From handstand to support</b> From a controlled handstand, to a "frog"/ a planche (body straight) on elbows/ a planche with straight arms. Legs straight (not in DB610). Legs may be separated.			DB610  handstand to frog		DB1010  handstand to planche
<b>From handstand to straddle pike or pike sitting support</b> Lowering from handstand to straddle pike/ pike sitting support. Legs must be straight the whole way.				DB811 	DB1011  legs together
<b>Circles</b> The turn is measured from the legs. The tolerance for any under or over rotation at the start and/or the end of an element is 45° in total. Legs and feet must be off the ground.			DB612  double leg circles 1 round	DB812  double leg circles ≥2 rounds	DB1012  flared leg circles 2 rounds
<b>Russian wendel-swing</b> The full turn (360°) is measured from the shoulders. The tolerance for any under or over rotation at the start and/or the end of an element is 45° in total. Legs and feet must be off the ground.					DB1013 

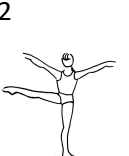
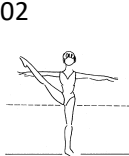
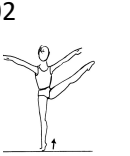
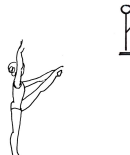
## 1.2 Standing Balances

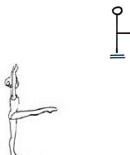
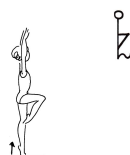
There must be a recognised shape when performing balances on one leg. The whole body must be held in a static position for at least two seconds without any additional choreographed movements. In case the body or part of the body like an arm is moving slightly, but the elevated leg is kept in the required position and the supporting leg is not moving, the difficulty is still given. Leg separation and legs straight (not applicable to lifted leg in SB404) requirements need to be fulfilled (15° tolerance). Showing additional flexibility does not affect the difficulty value. **For upright body position the central line along the length of the torso may be no more than 30° from vertical.** For straight body position the tolerance is 20°. For horizontal body position the tolerance is 15°. When the free leg is bent (forward/side) the heel is used to define the angle to the hip. If not otherwise mentioned the placement of arms is optional for the team. The supporting leg needs to be straight (15° tolerance). The body position must be according to the definition of the element, e.g. upright body position, upper body at horizontal, straight body position, straight legs and standing on tiptoes when required.

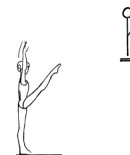
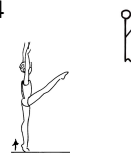
Standing Balances	0.2	0.4	0.6	0.8	1.0
<b>Side balance with help of hand</b> Free leg on the side with help of hand. Body in upright position. Leg separation/tiptoes position defines the element. In SB1001 the free leg is held using one hand, two hands or arm. The whole team needs to hold the free leg in the same way.			SB601  120°	SB801  120° on tiptoes	SB1001  180°
<b>Side balance without help of hands</b> Free leg on the side without help of hand. Body in upright position. Leg separation/ tiptoes position defines the element.		SB402  90°		SB802  120°	SB1002  120° on tiptoes
<b>Frontal balance</b> Free leg in front with help of hand/hands. Leg separation/ tiptoes position defines the element. <b>Body in upright position.</b>			SB603  120°	SB803  120° on tiptoes	
<b>Frontal balance</b> Free leg in front without help of hand/ hands. Leg separation/ tiptoes position defines the element. In SB404 the toe is placed on the knee. <b>Body in upright position.</b>	SB204  90°	SB404  on tiptoes	SB604  90° on tiptoes	SB804  120°	SB1004  120° on tiptoes

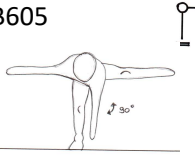
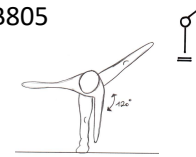
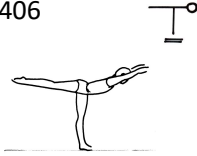
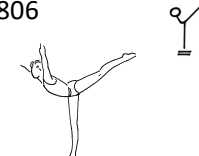
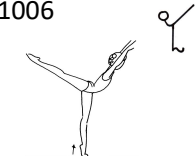
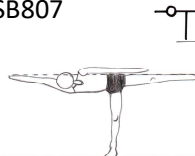
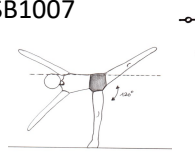
Standing Balances continued	0.2	0.4	0.6	0.8	1.0
<p><b>Side balance</b> Upper body at horizontal, free leg to the side. Heel defines the angle to the hip. Leg separation defines the element.</p>			<p>SB605</p>  <p>90°</p>	<p>SB805</p>  <p>120°</p>	
<p><b>Scale</b> Upper body must be horizontal or above. Leg separation/tiptoes position defines the element.</p>		<p>SB406</p>  <p>90°</p>		<p>SB806</p>  <p>120°</p>	<p>SB1006</p>  <p>120° on tiptoes</p>
<p><b>Scale sideways without help of hand</b> Upper body must be horizontal (body position is measured from the upper side of the torso, 15° tolerance) In SB807 the upper body and the leg must stay in the frontal plane. Leg separation defines the element (measured from the heel). The hip must be extended, upper body not twisted. (15° tolerance)</p>			<p>SB807</p>  <p>90°</p>	<p>SB1007</p>  <p>120°</p>	









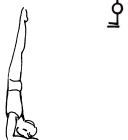
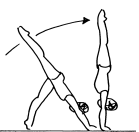

### 1.3 Hand Supportive Balances

In a hand supportive balance, the body is held in a static position for at least two seconds. Only the hands are touching the floor (except in headstand HB201 and forearm balance HB601). There must be a recognised shape without any additional movement. The hip angle, straight legs and leg separation/legs together requirement must be fulfilled (15° tolerance). Showing smaller hip angle does not affect the difficulty value. Body must be straight according to the definition of the element (30° tolerance). The body line must be horizontal according to the definition of the element (20° tolerance).

In case the body or part of the body like the legs are moving slightly, but the hands are not moving, the difficulty is still given.

Leaning on the arms is not allowed in pike sitting supports where the legs are lifted over the horizontal level.

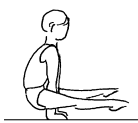
In handstand HB1001, the team need to have the legs in the same position and above hip level. No need to have straight legs together.

Hand Supportive Balances	0.2	0.4	0.6	0.8	1.0
<b>Headstand/Handstand</b> In HB201 head is allowed on floor, straight legs together. In HB601 no leaning on head, straight legs together. In HB1001 the arms must be straight (45° tolerance) and the legs above hip level. The placement of legs must be the same for the whole team (45° tolerance on the posture and position of legs).	HB201 		HB601 		HB1001 
<b>Planche on elbows/straight arms, legs separated</b> Straight legs (except HB202). Leg separation 45°. The body is supported on both hands on elbows or straight arms. Hands may be turned out at the wrist or pointing towards the feet. The body line horizontal (not in HB202). When performing HB802, arms must be straight (15° tolerance).	HB202 	HB402 		HB802 	
<b>Planche on elbows/straight arms, legs together</b> Straight legs together (except HB403). The body is supported on both hands (except HB403) on elbows or straight arms. Hands may be turned out at the wrist or pointing towards the feet. The body line horizontal. When performing HB1003, arms must be straight (15° tolerance).		HB403 	HB603 		HB1003 
<b>Straddle pike sitting-support</b> Straight legs. Hands placed in front or back (HB404) or front and back (HB204), leg separation 45°. Leaning on arms is not allowed when legs are lifted higher than parallel to the floor. Both hands are placed at the side of the body, close to the hips. Body is supported with only the hands in contact with the floor.	HB204 	HB404 	HB604  45°	HB804  90°	

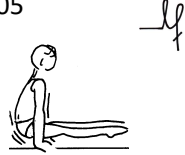
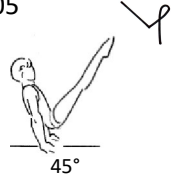
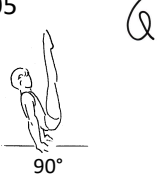
Hand Supportive Balances continued	0.2	0.4	0.6	0.8	1.0
<p><b>Pike sitting- support</b>            Straight legs together. When legs are lifted higher than parallel to the floor no leaning on the arms is allowed. Both hands are placed at the side of the body, close to the hips. Body is supported only with the hands in contact with the floor.</p>		HB405 		HB805 	HB1005 











## 2 Jumps, including Leaps and Hops (J)











The text contains the definition of the element and the picture is a guideline





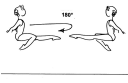

A recognised body shape (position) must be shown in the air. E.g. straight arms and legs, straight shoulder angle and correct body line when required.  
 The shape during flight, twisting and landing must be according to the definition of the element. If not otherwise mentioned, the placement of the twist is optional, but all gymnasts must perform the same variation.  
 The leg separation/legs together and hip angle (15° tolerance). The tolerance for any under or over rotation at the start and/or the end of an element is 45° in total. Showing additional flexibility or smaller hip/knee angles does not affect the difficulty value. In the take-off and landing, the hip defines the degree of the turn/twist.  
 The whole team must perform the same jump with arms and legs in the same position. If not otherwise mentioned, the placement of arms is optional for the team.  
 When landing in front laying support the body must be horizontal before landing (20° tolerance). That means that shoulders, hips and heels are all on the same level.  
 When performing with the foot at shoulder/head height, the lowest part of the foot defines height. The whole foot (both heel and toes) must be at the required height. **Head height: The point where the neck reaches the base of the skull or above. Shoulder height: Above the top of the shoulder.**  
 No more than three steps (walking or running) are allowed before any jump, according to the choreography.  
 In jumps with twists all gymnasts must start the jump facing the same direction, according to the choreography. (Valid only in jumps, not in leaps and hops).  
**In twisting leaps and hops, the hips must be facing the same direction as the path taken by the gymnast at the point of take-off.**



### 2.1 Jumps

A jump takes off from two feet and lands on two feet (a) or lands on one foot (b) or in front laying support c)



2.1A Jumps starting and landing with two feet	0.2	0.4	0.6	0.8	1.0
<b>Stretched jump with twisting</b> Straight body during the flight. Twist finished in the air. Placement of arms is optional.		J401  360°	J601  540°	J801  720°	
<b>Tuck jump with twisting</b> Tucked position (hip and knee angle 90°, 15° tolerance) visible during the jump. Twist completed in the air. Placement of arms is optional.				J802  360°	J1002  540°
<b>Straddle pike jump with or without twisting</b> Leg separation 135° and clear pike 90° (15° tolerance in leg separation and hip angle) legs straight without a kick.			J603  180°	J803  180°	J1003  360°



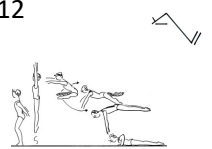
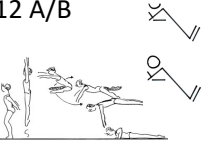
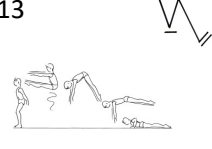
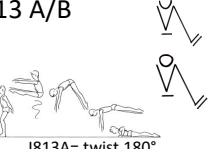
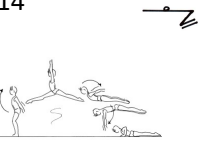
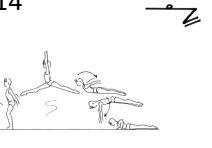

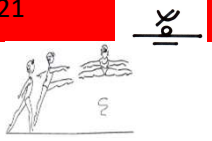
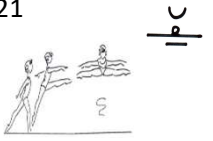
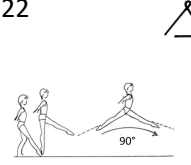
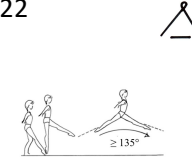
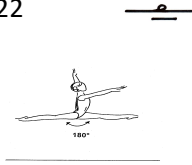
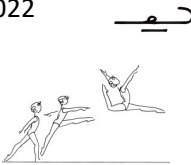
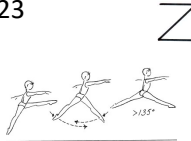
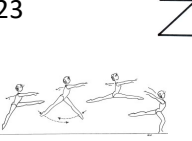
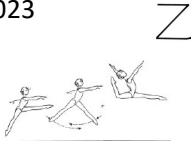
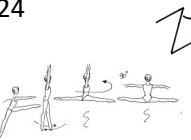
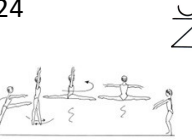
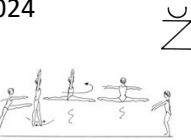

2.1A Jumps starting and landing with two feet	0.2	0.4	0.6	0.8	1.0
<b>Sheep jump</b> Head back. Height of the feet defines the jump. Legs may be separated. No tolerance in feet height.				J804  Feet at shoulder height	J1004  Feet at head height
<b>Sheep jump twisted</b> The feet must reach the shoulder height somewhere during the jump. No tolerance in height of feet. Twist must be performed during the flight.					J1005  Twist 180°
<b>Double stag jump with or without twisting</b> Right 'stag'-position must be visible during the jump: both legs bent 90°, leg separation 135° (15° tolerance), height of the rear foot or twists defines the element. No tolerance in foot height. The turn must be fulfilled during the flight.	J206  $>135^\circ$	J406  180°			J1006  Double stag ring Foot at head height
<b>Wolf jump with or without twisting</b> One leg extended, other tucked. Hip and bent knee angles 90° (15° tolerance). When twisting, the turn must be performed during the flight.	J207 	J407  180°		J807  360°	
<b>Split jump</b> In J408 and J1008 both legs must be straight, no kick. Leg separation defines the jump.		J408  Leg separation 135°			J1008  Leg separation 180°

2.1B Jumps starting with two feet and landing on one foot	0.2	0.4	0.6	0.8	1.0
<b>Sissone</b> Front leg minimum at 45° (no tolerance). In J1009 A/B no tolerance in foot height.		J409  Leg separation 135°		J809  Leg separation 180°	J1009 A/B  Foot at head height J1009A without twist J1009B with 180° twist
<b>Double stag jump with or without twisting</b> Right 'stag'-position must be visible during the jump: both legs bent 90°, leg separation 135° (15° tolerance), height of the rear foot or twists defines the element. No tolerance in foot height. The turn must be fulfilled during the flight.	J210  $>135^\circ$	J410  180°			J1010  Double stag ring Foot at head height

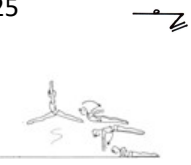
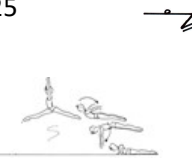
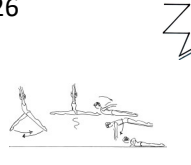
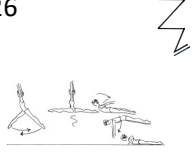
2.1C Jumps starting with two feet and landing in front laying support	0.2	0.4	0.6	0.8	1.0
<p><b>Tuck jump with or without twisting to front laying support</b></p> <p>Tucked position (hip and knee angle 90°, 15° tolerance) visible during the jump. When twisting 180° turn must be completed before tucked position. When twisting 360° or more turn must be ready before landing. Body must be horizontal before landing.</p>		<p>J411</p> 	<p>J611</p>  <p>180°</p>	<p>J811</p>  <p>360°</p>	
<p><b>Shushunova with or without twisting</b></p> <p>Leg separation 135° and clear pike 90° (15° tolerance in leg separation and hip angle) before landing in front laying support. Body must be horizontal before landing. When twisting the turn must be performed during the flight.</p>			<p>J612</p> 	<p>J812 A/B</p>  <p>J812A=180° J812B=360°</p>	
<p><b>Pike jump to front laying support with or without twisting</b></p> <p>Clear pike 90° (15° tolerance) before landing in front laying support, straight legs together. Body must be horizontal before landing. When twisting, the turn must be performed during the flight.</p>			<p>J613</p> 	<p>J813 A/B</p>  <p>J813A= twist 180° J813B= twist 360°</p>	
<p><b>Split jump landing to front laying support</b></p> <p>Legs must be straight, no kick. Leg separation defines the jump. Body must be horizontal before landing.</p>			<p>J614</p>  <p>Leg separation 135°</p>	<p>J814</p>  <p>Leg separation 180°</p>	

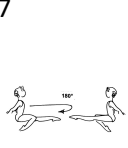
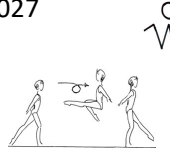
<b>2.2 Leaps</b> A Leap takes off from one foot and lands on the other (a) or both feet (b) or front laying support (c) (exceptions: switch leaps in rows 23 and 24)					
<b>2.2A Leaps starting on one foot and landing on the other</b>	<b>0.2</b>	<b>0.4</b>	<b>0.6</b>	<b>0.8</b>	<b>1.0</b>
<b>Stretched leap with twisting</b> Body straight during the flight. Twist finished in the air. Placement of arms is optional.		J415  360°	J615  540°		
<b>Cat leap twisting</b> Bent legs. Leg change during the flight. Thighs must be horizontal (no tolerance) somewhere during the flight. The turn must be fulfilled in the air.			J616  360°	J816  540°	J1016  720°
<b>Scissors leap</b> Straight legs. Leg change during the flight. First leg must reach horizontal (no tolerance).			J617  Leg separation 135°		
<b>Scissors leap 180° (Entrelacé)</b> Straight legs. Leg change during the flight. First leg must reach horizontal (no tolerance). Twisting during the flight. Leg separation after the turn defines the element.		J418  Leg separation 90°		J818  separation 135°	J1018  Leg separation 180°
<b>Butterfly</b> legs separated, upper body at horizontal, legs above horizontal level (no tolerance)  A stomach upwards B stomach downwards					J1019A/B  Butterfly fw or bw







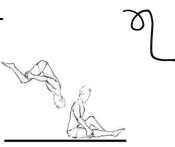

2.2A Leaps starting on one foot and landing on the other	0.2	0.4	0.6	0.8	1.0
<b>Double stag leap</b> Right 'stag'-position must be visible during the leap: both legs bent 90°, leg separation 135° (15° tolerance), height of the rear foot or twists defines the element. No tolerance in foot height.		J420 		J820  Double stag ring Foot at head height	
<b>Split leap to straddle pike position with twisting</b> Leg separation 135°, clear pike 90° and legs straight without a kick.			J621  Leg separation 135° twist 90°	J821  Leg separation 135° twist 180°	
<b>Split leap forward</b> In J222, J422 and J822 both legs must be straight, no kick. Leg separation defines the leap. In J1022 horizontal ring-leap: first leg straight and horizontal, foot at shoulder level or higher (no tolerance).	J222  Leg separation 90°	J422  Leg separation 135°		J822  Leg separation 180°	J1022  Leg separation 180°
<b>Switch leap</b> In J623 and J823 both legs must be straight, no kick. First leg must swing forwards at least 45° before the leg change. Leg separation after leg change defines the leap. In J1023 first leg must be straight. Foot must be at shoulder level or higher (no tolerance).			J623  Leg separation 135°	J823  Leg separation 180°	J1023  Foot at shoulder height leg separation 180°
2.2B Leaps starting on one foot and landing on two feet	0.2	0.4	0.6	0.8	1.0
<b>Switch leap twisting</b> Both legs must be straight, no kick. First leg must swing forwards at least 45° before the leg change. Leg separation after leg change defines the leap. Twist must be finished during the flight.			J624  Leg separation 135° twist 90°	J824  Leg separation 135° twist 180°	J1024  Leg separation 180° twist 180°

2.2C Leaps starting with one foot and landing in front laying support	0.2	0.4	0.6	0.8	1.0
<b>Split leap forward landing to front laying support</b> Legs must be straight, no kick. Leg separation defines the value of the leap. Body must be horizontal before landing.			J625  Leg separation 135°	J825  Leg separation 180°	
<b>Switch leap to front laying support</b> Both legs must be straight, no kick. First leg must swing forwards at least 45° before the leg change. Leg separation after leg change defines the leap. Body must be horizontal before landing.			J626  Leg separation 135°	J826  Leg separation 180°	
<b>2.3 Hops</b> <span style="float: right;">A Hop takes off from one foot and lands on the same foot.</span>					
	0.2	0.4	0.6	0.8	1.0
<b>Wolf hop with or without twisting</b> One leg extended, other tucked. Hip and bent knee angles 90° (15° tolerance). When twisting, the turn must be performed during the flight.	J227 	J427  180°			J1027  360°
<b>Stretched hop with twisting</b> Body straight during the flight. Twist finished in the air. Placement of arms is optional.				J828  360°	J1028  540°
<b>Tuck hop with twisting</b> Tucked position (hip and knee angle 90°, 15° tolerance) visible during the jump. Twist finished in the air. Placement of arms is optional.					J1029  360°



### 3 Acrobatic Elements

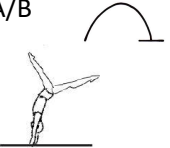

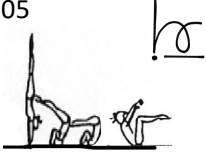
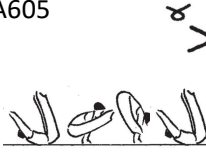
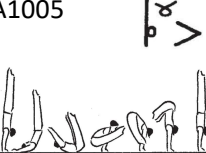

The text contains the definition of the element and the picture is a guideline

Acrobatic elements must comply with norms of TeamGym. Arms, legs and shoulder angle must be straight when required. Body shape must be according to the elements definition. Different landing positions are allowed as long as they are feet first (in absence of any other description). In elements with a twist the tolerance is 45° from the nominal twist rotation. Some elements have different variations (A/B/C). No more than three steps (walking or running) are allowed before any difficulty element, according to the choreography. In elements with turns in handstand the team needs to show the handstand (with straight arms, straight hips and straight legs together) before turning. When turning, legs can be separated (above hip level, whole team the same position). There is no need for the team to perform the turn to the same direction. The turn is measured at the hips, 45° tolerance.

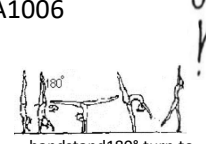
3.1 Forward Elements	0.2	0.4	0.6	0.8	1.0
<p><b>Forward saltos from one foot to one foot</b> Exception: A601 - landing in sitting position</p> <p>In A601 the landing in sitting position must be with hands and foot before any other part of the body.</p>			<p>A601 </p> <p>sitting salto</p>	<p>A801 </p> <p>tucked salto fwd</p>	<p>A1001 </p> <p>piked salto</p>
<p><b>Forward saltos from one foot to two feet</b></p>				<p>A802 </p> <p>tucked salto fwd</p>	<p>A1002  180°</p> <p>tucked salto fwd 180°</p>
<p><b>Forward saltos from 2 feet</b> <b>A version:</b> from two feet to two feet <b>B version:</b> from two feet to two feet with half twist</p>			<p>A603A/B </p> <p>tucked salto/ tucked salto 180°</p>	<p>A803A/B  180°</p> <p>piked salto/ piked salto 180°</p>	
<p><b>Forward handspring elements</b> A version: from one foot to one foot B version: from one foot to two feet</p>			<p>A604A/B </p> <p>handspring</p>		<p>A1004 </p> <p>free handspring</p>

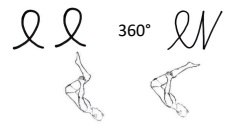

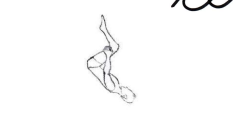
Forward Elements 3.1 continued	0.2	0.4	0.6	0.8	1.0
<p><b>Forward roll elements</b> Bending arms when rolling is optional for the team.</p> <p>In A605 and A1005: Feet must not touch the floor. Momentum from the forward roll is used all the way through the element. (no stop, no head on the floor)</p>	<p>A205</p>  <p>handstand to forward roll</p>		<p>A605</p>  <p>endo roll</p>		<p>A1005</p>  <p>endo roll to handstand</p>
<p><b>Forward walkover elements</b></p>		<p>A406</p>  <p>walk over forwards</p>			<p>A1006</p>  <p>handstand 180° turn to walk over fw</p>

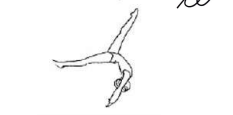
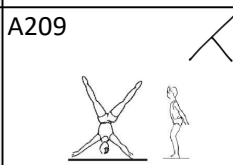
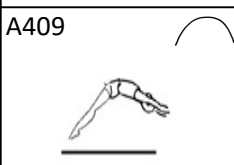
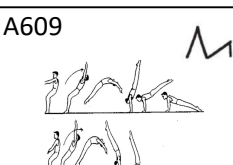
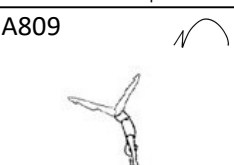
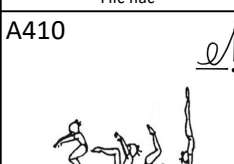
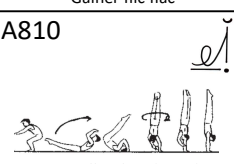
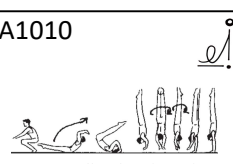
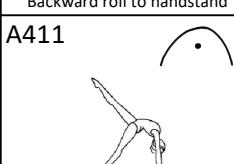
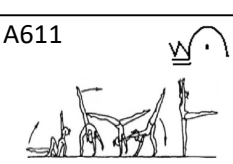
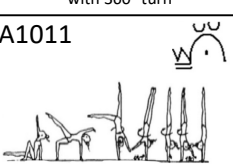
3.2 Backward Elements	0.2	0.4	0.6	0.8	1.0
<b>Backward saltos</b> Take-off and landing on two feet  <b>A version:</b> tucked/straight salto without twisting <b>B version:</b> tucked/straight salto with full twist <b>C version:</b> piked salto			A607A/B/C  Tucked/piked salto bw		A1007A/B  Straight salto bw
<b>Backward gainer saltos</b> A608 and A808: take-off from 1 leg, landing on 2 legs A1008: take-off from one leg, landing on the other leg			A608  Gainer salto tucked	A808  Gainer salto piked	A1008  Gainer layout
<b>Backward elements</b> A609 passes through handstand to finish in front support. In A809 take-off is from one leg to land on the other leg	A209  Roundoff	A409  Flic flac	A609  Flic flac to front support	A809  Gainer flic flac	
<b>Backward roll elements</b> Elbow flexion is optional.		A410  Backward roll to handstand		A810  Bw roll to handstand with 180° turn	A1010  Bw roll to handstand with 360° turn
<b>Backward walkover elements</b>		A411  Walk over bw	A611  Walk over bw from sitting (valdez)		A1011  Valdez with 360° turn in handstand

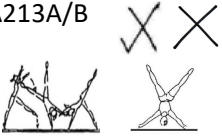
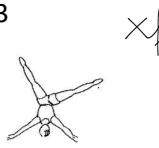
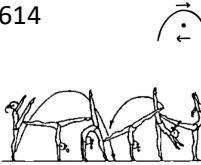
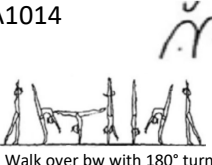
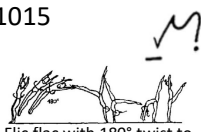
3.3 Sideways Elements	0.2	0.4	0.6	0.8	1.0
<p><b>Sideways salto</b>  The sideways salto can vary in terms of take off direction (between forwards and sideways with 45° tolerance), taking off/landing on one or two feet, and also body shape. However, the skill must be performed the same for the whole team.</p>					A1012  Sideways salto
<p><b>Sideways elements</b>  A version: cartwheel with one hand  B version: cartwheel with two hands  In A213 the team may choose to use the first or the second hand in a cartwheel, but it must be the same for the whole team.</p>	A213A/B  Cartwheel with one or two hands				A1013  Free cartwheel
3.4 Mixed Elements	0.2	0.4	0.6	0.8	1.0
<p><b>Mixed walkover elements</b></p>			A614  Walk over fw - bw (tic toc)		A1014  Walk over bw with 180° turn to walkover fw
<p><b>Mixed elements</b></p>					A1015  Flic flac with 180° twist to handstand with walkover fw or to handspring

## 4 Group Elements

The text contains the definition of the element and the picture is only for an example

All gymnasts of the team have to take part in the group element and play an active role in either a visible lift off the floor or a throw which can be done together with the whole team or in groups of at least 3 gymnasts. The group element must be performed at the same time according to the choreography, in groups or as a whole team. Different groups must perform group elements with the same code number but the elements do not need to be the same. Rotations and twists are always in reference to the gymnast(s) being lifted or thrown. (no tolerance in rotation/twist)

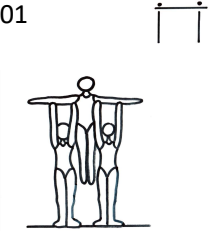
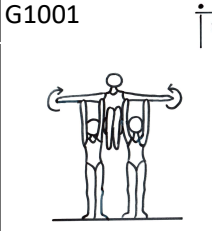
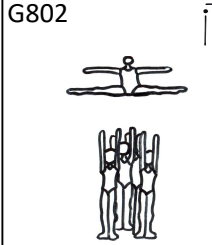
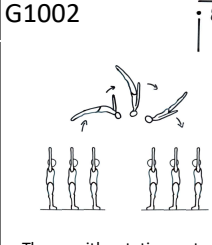
Group elements	0.2	0.4	0.6	0.8	1.0
<p><b>Lift</b>                      In G601 the lifted gymnast(s) must be off the ground for at least 2 seconds.                      In G1001 the rotation/twist during the lift is measured from ground to ground.</p>			<p>G601</p>  <p>Lift</p>		<p>G1001</p>  <p>Lift with rotation or twist (<math>\geq 180^\circ</math>)</p>
<p><b>Throw</b>                      The thrown gymnast(s) must show clear flight, free of supporting gymnasts.                      In G1002 the rotation/twist during the throw is measured during the free flight phase.</p>				<p>G802</p>  <p>Throw</p>	<p>G1002</p>  <p>Throw with rotation or twist (<math>\geq 90^\circ</math>)</p>

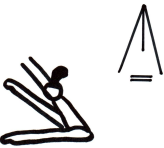
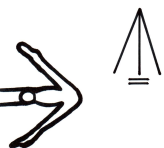
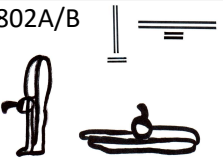
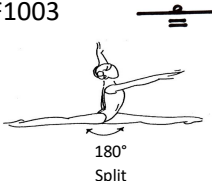
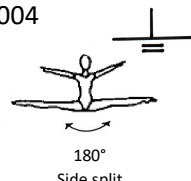
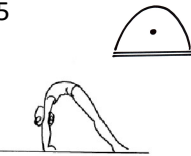
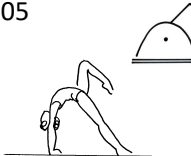
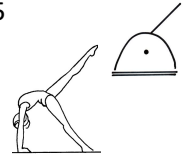
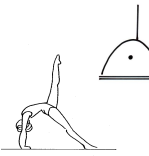
5 Flexibility Elements		The text contains the definition of the element and the picture is a guideline			
All gymnasts of the team have to do the same flexibility element, which must be performed at the same time according to the choreography. In the flexibility element, the position must be clearly shown, but does not have to stay still. The legs must be straight and the leg separation requirement must be fulfilled (15° tolerance). Showing additional flexibility or smaller hip/knee angles does not affect the difficulty value. The upper body fold requirement must be totally fulfilled, no tolerance.					
Flexibility elements	0.2	0.4	0.6	0.8	1.0
<b>Straddle pike sitting fold</b> Leg separation must be at least 90° F401: upper body folded 45° F801: upper body folded all the way down, chest on the floor		F401  Japana 45°		F801  Japana	
<b>Piked fold</b> <b>A version: Standing</b> <b>B version: Sitting</b> In piked fold the chest/shoulders must touch straight legs. Legs must be together (15° tolerance).				F802A/B  Standing/sitting pike fold	
<b>Split with 180° leg separation</b> The position of the upper body is optional for the team.					F1003  180° Split
<b>Side Split with 180° leg separation</b> The position of the upper body is optional for the team.					F1004  180° Side split
<b>Bridge</b> Position and angle of the free leg defines the element. Shoulders must be at least on top of the hands (as defined by a vertical straight line through the centre of the shoulders). No tolerance in free leg height.		F405 	F605  Thigh vertical	F805  Leg 45° from vertical	F1005  Leg vertical